

## Positioning Tables

NFM

NH2 - AL

## Slides

NE - AL

### **Latest version of the catalogs**

You can always find the latest version of our catalogs in the Download area of our website.

### **Disclaimer**

This publication has been compiled with great care and all information has been checked for accuracy. However, we can assume no liability for incorrect or incomplete information. We reserve the right to make changes to the information and technical data as a result of enhancements to our products. Reprinting or reproducing, even in part, is not permitted without our written consent.



	Page number
<b>1</b> Positioning Tables NH2	<b>5</b>
1.1 Positioning Tables NH2	5
1.2 Options	5
1.3 Drawings	6 + 7
1.4 Dimension Tables	6 + 7
<b>2</b> Slides NE	<b>8</b>
2.1 Slides NE	8
2.2 Drawings	9
2.4 Dimension Tables	9
<b>3</b> Positioning Tables NFM	<b>27</b>
3.1 Positioning Tables NFM	11
3.2 Options	11
3.3 Drawings	12 + 13
3.4 Dimension Tables	12 + 13



## 1.0 Positioning Tables NH2

### 1.1 Positioning Tables NH2-40/40-AL, NH2-65/65-AL, NH2-110/110-AL



Type ... - ML



Type ... - MS

Single axis stages with SCHNEEBERGER linear bearings Type R2-RF. Manual positioning with micrometer, reading accuracy 0.01mm. Table parts are lightly loaded onto the micrometer screw by a tension spring. Design is available with or without micrometer, with or without spring. Micrometer fastening on the side or front of the stage. Tables of the same size can easily be assembled into 2 axis configuration. Standard strokes 13/13 and 25/(40)mm. Special hole patterns or strokes on request. All designs with a clamping system on the side of the stage. Table parts in aluminium anodised. Linear bearings in corrosion resistant steel. Tables can be integrated in any plane (micrometer below stage in vertical orientation!).

### 1.2 Options

- OF without tension spring
- MF with tension spring
- ML Micrometer front
- MS Micrometer side

Clamping standard right. Can be easily changed from right to the left side by the customer. (Except version MS)

# 1.0 Positioning Tables NH2 Technical data

## 1.3 Drawings

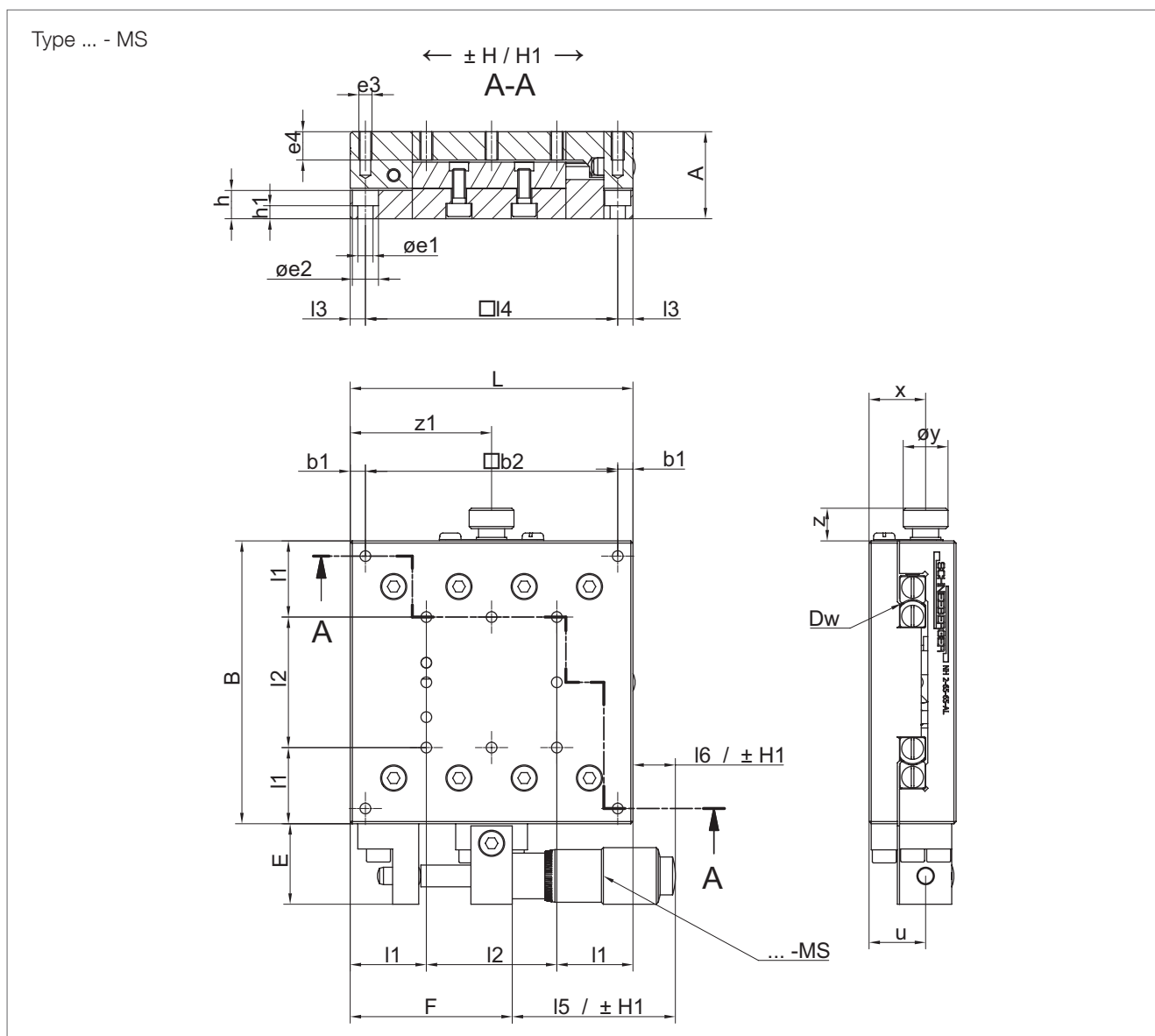

## 1.4 Dimension Tables

Type	Dimensions (mm)																	
	A	B	H	H1	Dw	L	l1	l2	l3	l4	l5	l6	F	F1	b1	b2	h	h1
NH2-40/40-AL	19	40	± 6.5	± 6.5	R2	40	-	-	4	32	37.5	37.5	39.5	21.5	4	32	6	2.5
NH2-65/65-AL	20	65	± 6.5	± 6.5	R2	65	17.5	2x15	3.5	58	37.5	9.75	37.25	21.5	3.5	58	6.5	3
NH2-110/110-AL	25	110	± 20	± 12.5	R2	110	25	2x30	6	98	80.4	16.4	46	30.5	6	98	8	3.5

**1.0** Positioning Tables NH2 Technical data

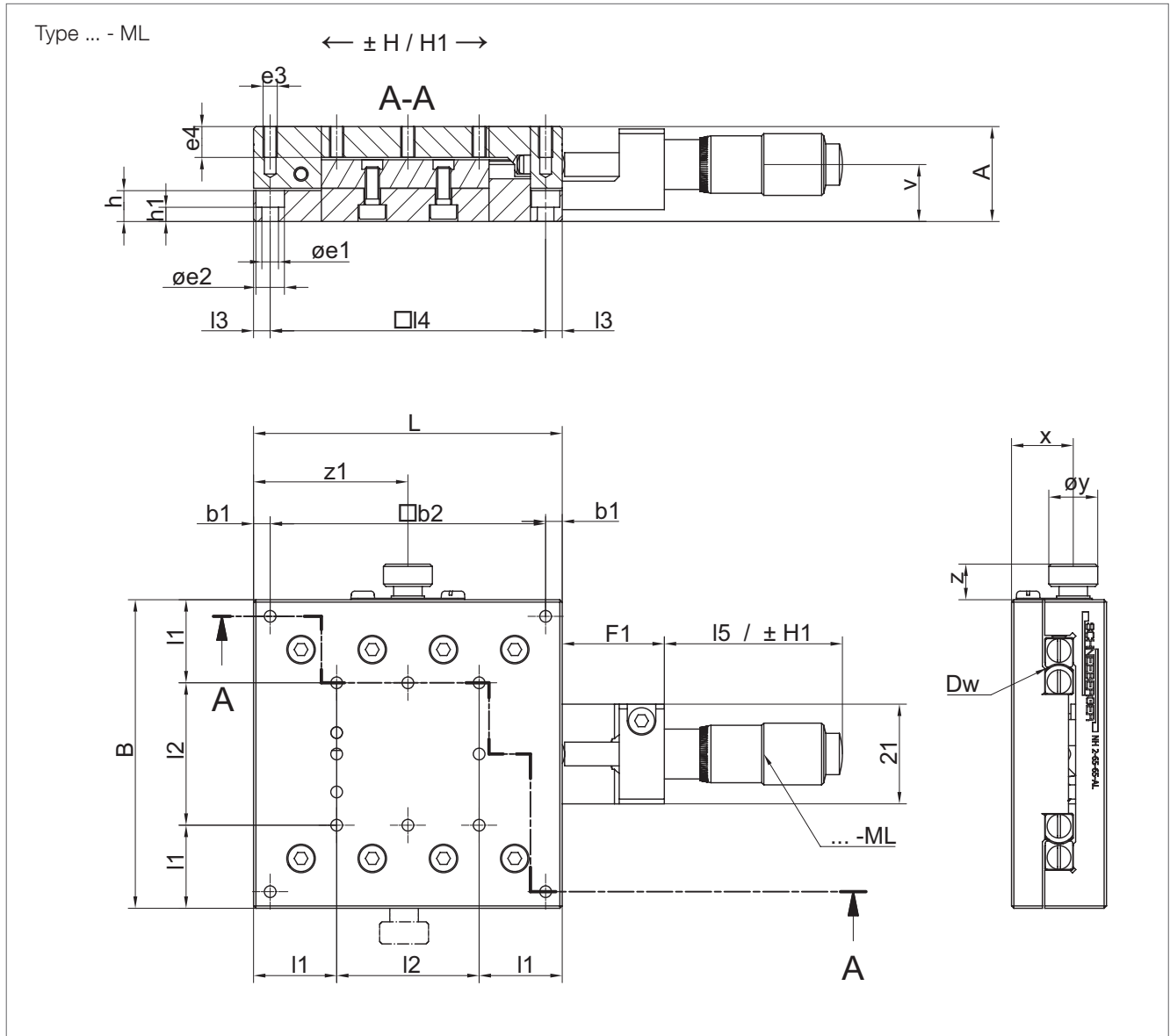

Type	Dimensions (mm)										Load capacity / Torque / Weight			
	e1	e2	e3	e4	u	v	x	y	z	z1	C (N)	ML (Nm)	MQ (Nm)	Weight (kg)
NH2-40/40-AL	3.5	6	M3	6	11	10	13	10.3	7.5	20	425	2.7	3.9	0.2
NH2-65/65-AL	3.5	6	M3	6	13	12	13	10.3	7.5	32.5	850	7.5	13.5	0.4
NH2-110/110-AL	4.5	7.5	M4	8	15	13	16	15.3	9.8	55	1420	12.9	43.5	1.7





## 2.0 Slides NE

### 2.1 Slides NE 1, 2, 3 - AL

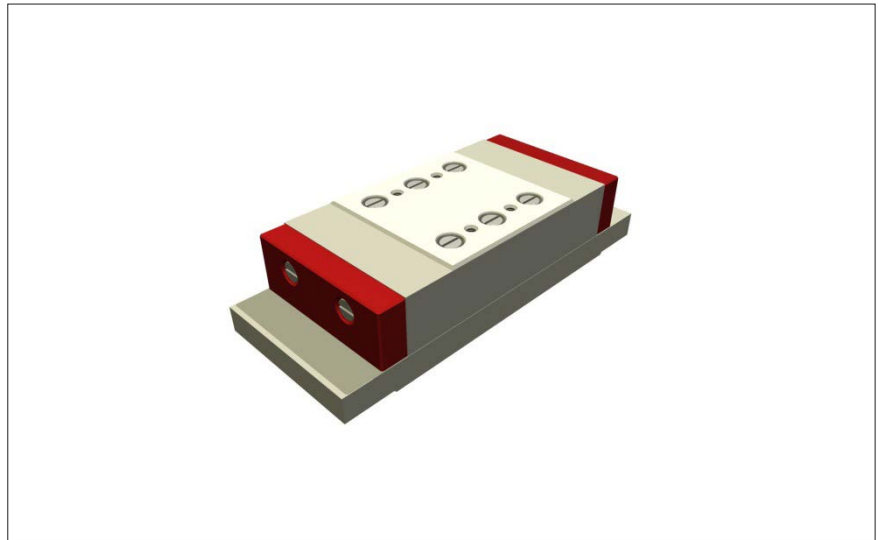

NE 1, 2, 3 - AL

Type NE AL slides are designed as closed model, which means that they can be sealed on all sides with small spacing between upper and lower sections. Prevent the ingress of dirt.

All sizes are equipped with linear bearing type R bearings. There are standardized attaching thread holes in the upper and lower section. Table parts in aluminium. Linear bearings in corrosion resistant steel (only NE 1 and NE 2). Tables can be integrated in any position.

2.2 Dimensions

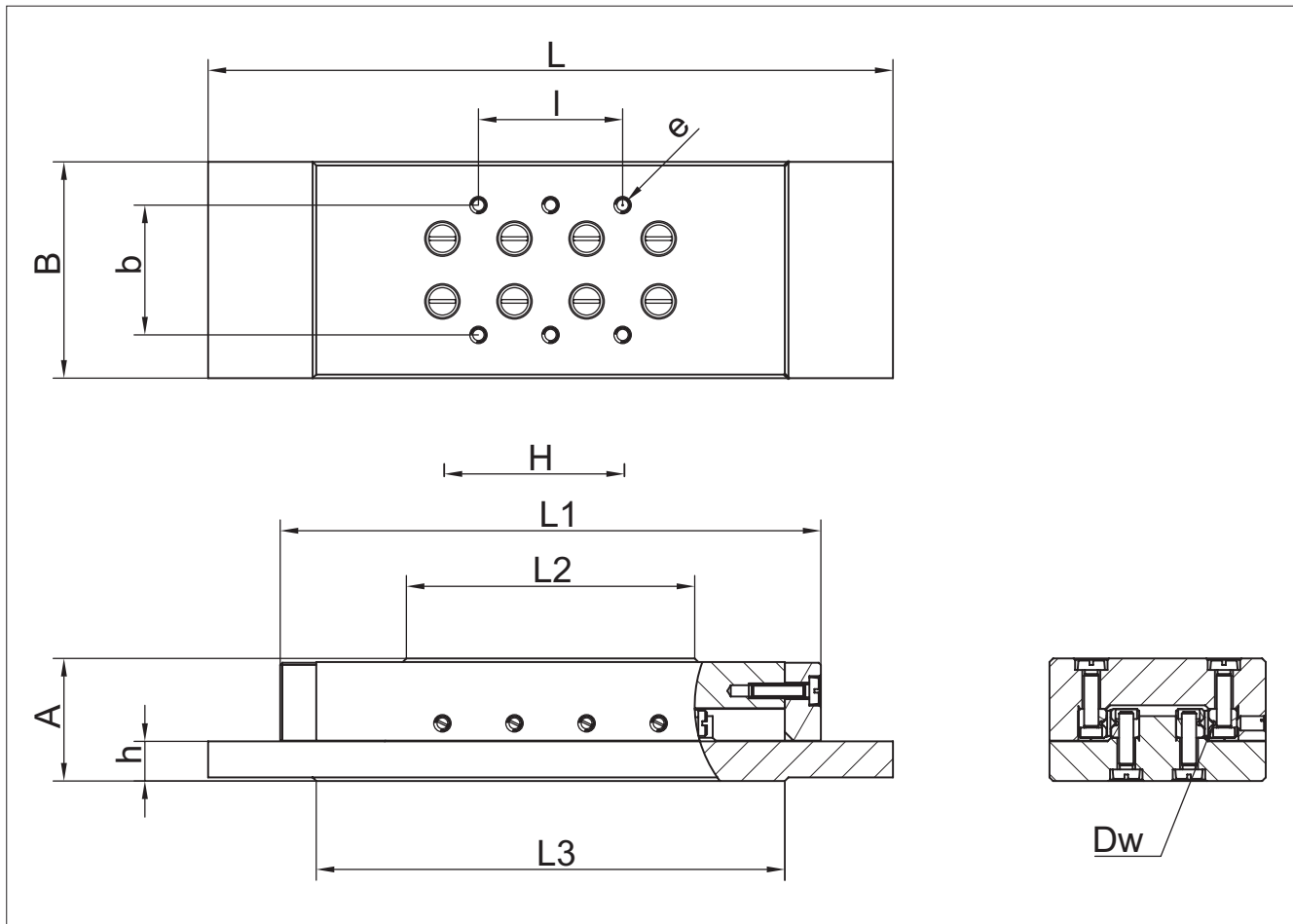

2.3 Dimension Tables

Type	Dimensions (mm)							
	A	B	H	Dw	L	L1	L2	L3
NE 1 - 45 - AL	17	30	10	1.5	55	45	20	45
NE 1 - 60 - AL			15		75	60	30	55
NE 1 - 75 - AL			20		95	75	40	65
NE 2 - 60 - AL	21	40	15	2	75	60	30	59
NE 2 - 85 - AL			25		110	85	45	74
NE 2 - 115 - AL			40		155	115	60	89
NE 3 - 100 - AL	28	60	30	3	130	100	50	84
NE 3 - 140 - AL			45		185	140	75	109
NE 3 - 180 - AL			60		240	180	100	134

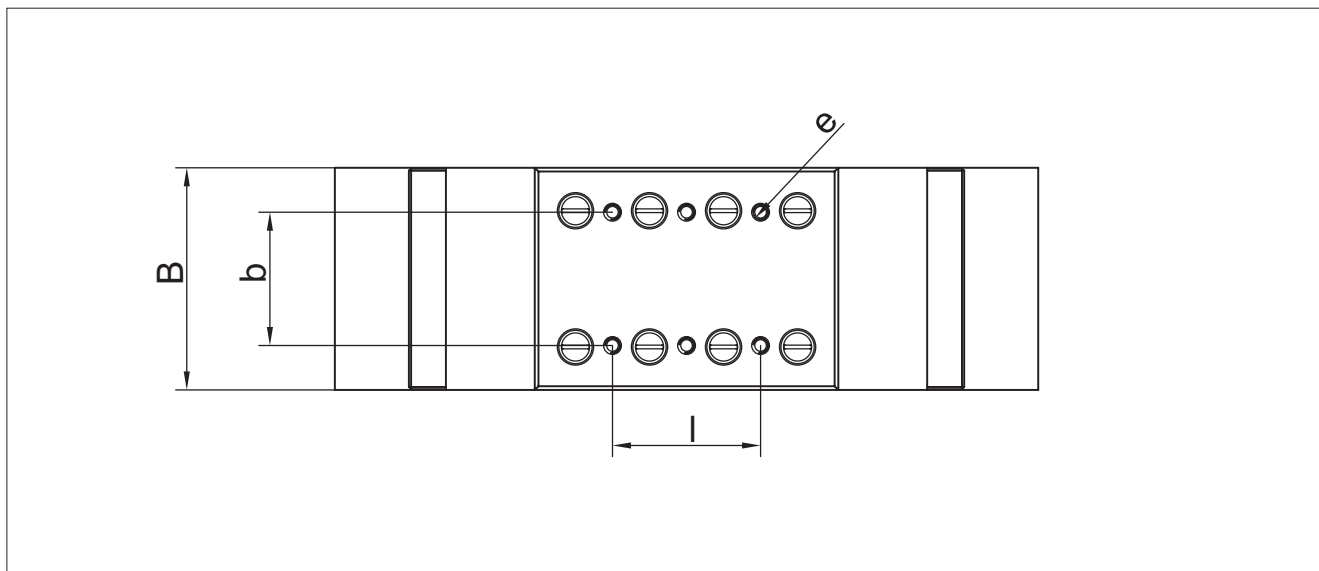

Type	Dimensions (mm)				Load capacity / Torque / Weight			
	e	l	b	h	C (N)	MI (Nm)	Mq (Nm)	Weight (g)
NE 1 - 45 - AL	M2x5	1x17	18	5.5	250	1.2	1.6	70
NE 1 - 60 - AL		1x10			350	1.86	2.3	90
NE 1 - 75 - AL		2x10			500	2.7	3.3	120
NE 2 - 60 - AL	M3x6	1x25	25	6.5	425	2.7	3.8	150
NE 2 - 85 - AL		1x15			680	4.7	6.1	220
NE 2 - 115 - AL		2x15			850	6.1	7.6	300
NE 3 - 100 - AL	M4x8	1x40	39	9	910	7.8	12.7	460
NE 3 - 140 - AL		1x25			1300	11.7	18.2	700
NE 3 - 180 - AL		2x25			1820	16.9	25.4	930



## 3.0 Positioning Tables NFM

### 3.1 Positioning Tables NFM 7 / 9 / 12

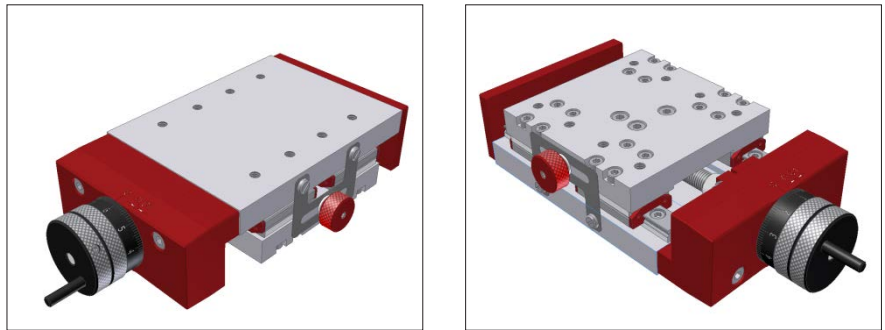

NFM7/9/12

Single axis manual driven stages with SCHNEEBERGER MINIRAIL – guideways. Manual positioning by a precision lead-screw, with anti- backlash nut and raduated drum, that can be set to zero position. Reading accuracy 0.01mm, strokes from 25mm to 150mm.

NFM is a modular system with options for table base and top plate lengths, to give strokes between 25 and 150mm. Table parts made in aluminium anodised, MINIRAIL linear guideways and lead screw in corrosion resistant steel. Stage can be integrated in any plane.

Special sizes and/or special attaching holes available on request. Optional clamping device on the side or directly on the lead screw (L dimension increased by 7mm). The clamping device can be mounted on either side of the stage (Size 7 without hand crank).

### 3.2 Options

- KR clamping right
- KL clamping left
- KS clamping on lead screw

Assembly to X-Y 2-axis stage without intermediate plate or to X-Y-Z 3-axis table with bracket are possible on request

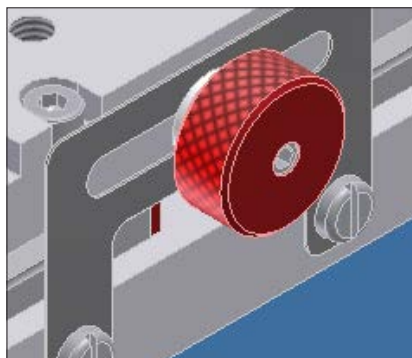

clamping left/right



clamping on lead screw

### 3.0 Positioning Tables NFM Technical data

#### 3.1 Dimensions

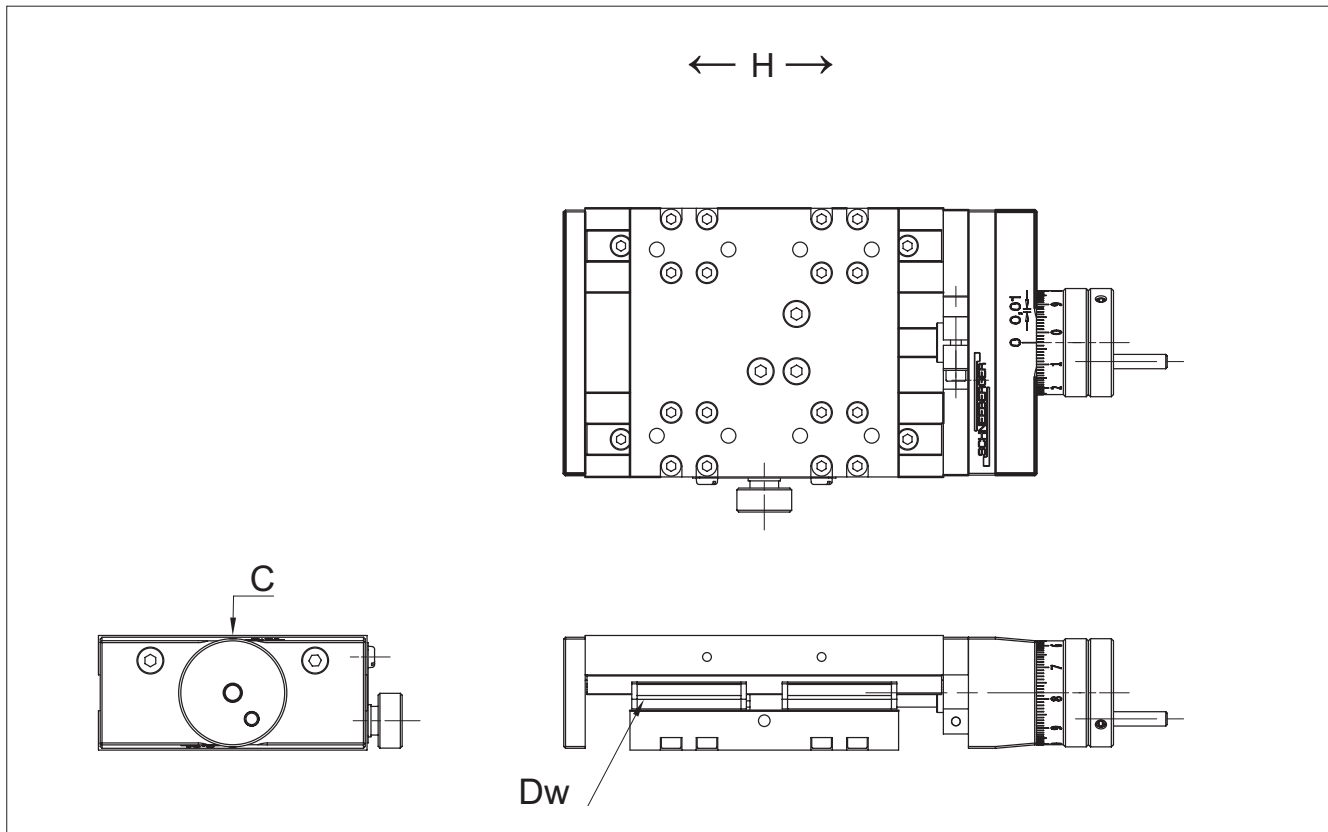

#### 3.2 Dimension Tables

Type	Dimensions (mm)															
	A	B	H	Dw	L	L1	I	I1	e1	e2	b	b1	c1	c2	c3	c4
NFM 7- 75/50	25	50	25	MNN 7	75	50	3x15	2x15	M4/8	M4x8	30	30	5	14	19.5	-
NFM 7-100/50			50		100	50	5x15	2x15								
NFM 7-125/50			75		125	50	3x30	2x15								
NFM 7-100/75			25		100	75	5x15	4x15								
NFM 7-125/75			50		125	75	3x30	4x15								
NFM 7-150/75			75		150	75	4x30	4x15								
NFM 9-100/75	32	75	25	MNN 9	100	75	3x20	3x20	M5x11	M5x11	52	52	6	19	21.5	15
NFM 9-125/75			50		125	75	4x20	3x20								
NFM 9-150/75			75		150	75	5x20	3x20								
NFM 9-175/75			100		175	75	7x20	3x20								
NFM 9-200/75			125		200	75	8x20	3x20								
NFM 9-125/100			25		125	100	4x20	4x20								
NFM 9-150/100			50		150	100	5x20	4x20								
NFM 9-175/100			75		175	100	7x20	4x20								
NFM 9-200/100			100		200	100	8x20	4x20								
NFM 12-150/100			36		100	50	MNN 12	150								
NFM 12-200/100	100	200		100		6x25		3x25								
NFM 12-250/100	150	250		100		4x50		3x25								

### 3.0 Positioning Tables NFM Technical data

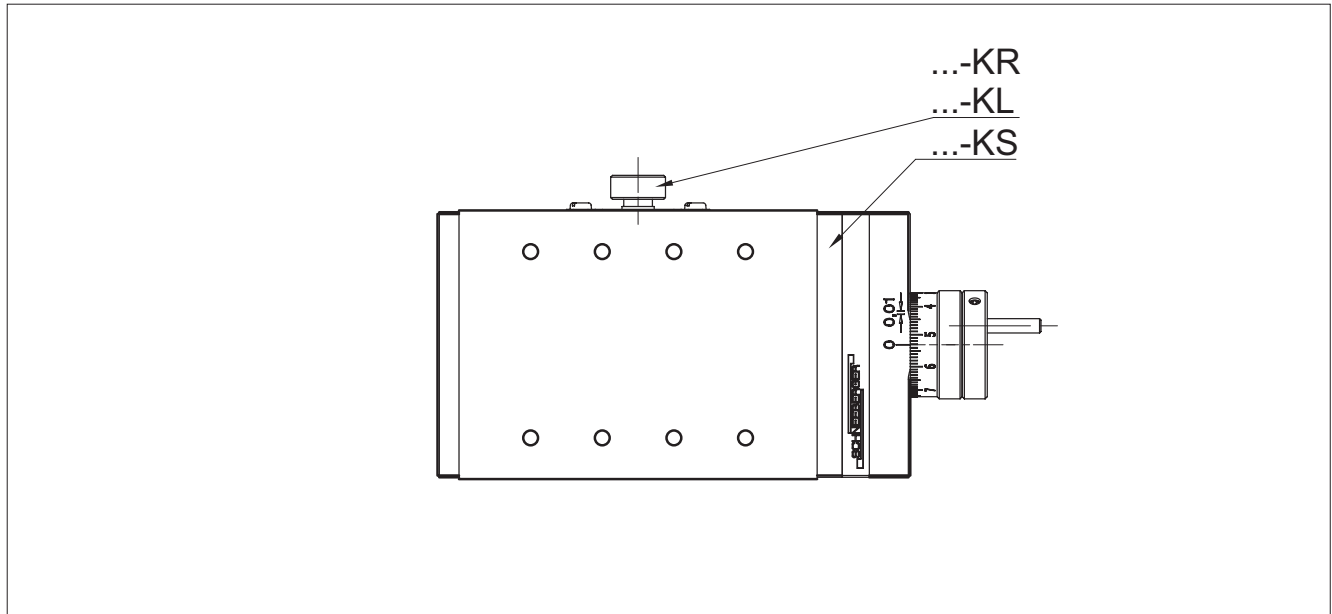

Type	Dimensions (mm)				Load capacity/Torque/Weight/Diameter + P				
	ø1	øy	x	z	C (N)	MI (Nm)	Mq (Nm)	Weight (~kg)	ø + P (mm)
NFM 7- 75/50	ø24	ø10.3	6.1	7.5	2960	37	47	0.4	M5x0.5
NFM 7-100/50								0.5	
NFM 7-125/50								0.6	
NFM 7-100/75								0.7	
NFM 7-125/75								0.8	
NFM 7-150/75								0.9	
NFM 9-100/75	ø30	ø15.3	8.2	9.8	5408	113	146	0.8	M8x1
NFM 9-125/75								0.9	
NFM 9-150/75								1	
NFM 9-175/75								1.1	
NFM 9-200/75								1.2	
NFM 9-125/100								1	
NFM 9-150/100						1.1			
NFM 9-175/100						1.2			
NFM 9-200/100						1.3			
NFM 12-150/100						ø34		ø15.3	
NFM 12-200/100	1.9								
NFM 12-250/100	2.1								

## PROSPECTUSES

- COMPANY BROCHURE
- CUSTOMIZED BEARINGS
- GEAR RACKS
- LINEAR BEARINGS and RECIRCULATING UNITS
- MINERAL CASTING SCHNEEBERGER
- MINI-X MINIRAIL / MINISCALE PLUS / MINISLIDE
- MONORAIL and AMS profiled linear guideways with integrated measuring system
- MONORAIL and AMS application catalog
- POSITIONING SYSTEMS
- SLIDES



## SCHNEEBERGER COMPANIES

### SWITZERLAND

SCHNEEBERGER AG  
St. Urbanstrasse 12  
4914 Roggwil/BE

Phone +41 62 918 41 11  
Fax +41 62 918 41 00

E-Mail:  
info-ch@schneeberger.com

### GERMANY

SCHNEEBERGER GmbH  
Gräfenau  
75339 Höfen/Enz

Phone +49 7081 782 0  
Fax +49 7081 782 124

E-Mail:  
info-d@schneeberger.com

### ITALY

SCHNEEBERGER S.r.l.  
Via Soldani 10  
21021 Angera (VA)

Phone +39 0331 93 2010  
Fax +39 0331 93 1655

E-Mail:  
info-i@schneeberger.com

### USA

SCHNEEBERGER Inc.  
44 Sixth Road,  
Woburn, MA 01801-1759

Phone +1 781 271 0140  
Fax +1 781 275 4749

E-Mail:  
info-usa@schneeberger.com

### INDIA

SCHNEEBERGER India Pvt. Ltd.  
406, Satra Plaza,  
Palm Beach Road, Sector 19D Vashi,  
400 703 New Mumbai

Phone +91 22 6461 0646  
+91 22 6461 1756

E-Mail:  
info-in@schneeberger.com

### JAPAN

Nippon SCHNEEBERGER K.K.  
Crane Toranomon Bldg 7F  
3-20-5 Toranomon, Minato-ku  
Tokyo 105-0001

Phone +81 3 6435 7474  
Fax +81 3 6435 7475

E-Mail:  
info-j@schneeberger.com

### CHINA

SCHNEEBERGER (Shanghai) Co., Ltd.  
Rm 606, Shang Gao International  
Building  
No. 137 XianXia Road  
200051 Shanghai

Phone +86 21 6209 0037 / 27  
Fax +86 21 6209 0102

E-Mail:  
info-cn@schneeberger.com

### KOREA

SCHNEEBERGER Korea Ltd.  
UNION Center Building  
1004, 10th FL  
310, Gangnam-Daero,  
Gangnam-Gu, Seoul,  
Korea 135-754

Phone +82 2 554 2971  
Fax +82 2 554 3971

E-Mail:  
info-kr@schneeberger.com

### SINGAPORE

SCHNEEBERGER LINEAR  
TECHNOLOGY PTE. Ltd.  
160 Paya Lebar Road, #05-04  
Orion Industrial Building  
409022 Singapore

Phone +65 6841 2385  
Fax +65 6841 3408

E-Mail:  
info-sg@schneeberger.com

### JAPAN

日本シュネーベルガー株式会社  
〒105-0001  
東京都港区虎ノ門3-20-5  
クレイン虎ノ門ビル7F

電話 03 6435 7474  
ファクス 03 6435 7475

Eメール:  
info-j@schneeberger.com

### CHINA

施耐博格 (上海) 传动技术有限公司  
上海市长宁区  
仙霞路137号盛高国际  
大厦606室, 上海 200051

电话 +86 21 6209 0027  
传真 +86 21 6209 0102

邮箱:  
info-cn@schneeberger.com

### KOREA

서울시 강남구 강남대로 310  
유니온센터 빌딩 1004호  
우편번호 135-754

전화 +82 2 554 2971  
팩스 +82 2 554 3971

이메일:  
info-kr@schneeberger.com

## SCHNEEBERGER MINERAL CASTING

### CZECH REPUBLIC

SCHNEEBERGER  
Mineralgusstechnik s.r.o  
Prumyslový park 32/20  
350 02 Cheb – Dolní Dvory

Phone +420 354 400 941  
Fax +420 354 400 940

E-Mail:  
info-mineralguss@schneeberger.com

### CHINA

SCHNEEBERGER Changzhou  
Precision Systems Co. Ltd.  
137 Hanjiang Road  
Changzhou New district  
213000 Changzhou, Jiangsu

Phone +86 519 8988 3938  
Fax +86 519 8988 5115

E-Mail:  
info-mineralcasting@schneeberger.com

### CHINA

施耐博格 (常州) 测试系统有限公司  
汉江路137, 常州新区, 常州213022

电话 +86 519 8988 3938  
传真 +86 519 8988 5115

邮箱:  
info-mineralcasting@schneeberger.com



## SCHNEEBERGER SALES DEPARTMENTS

### AUSTRIA AND SOUTH EAST EUROPE

Mobile +43 676 935 1035

E-Mail:  
info-a@schneeberger.com

### BENELUX

Mobile +31 6 5326 3929

E-Mail:  
info-nl@schneeberger.com

### DENMARK, SWEDEN

Mobile +31 6 5326 3929

E-Mail:  
info-nl@schneeberger.com

### FRANCE

Mobile +33 6 0941 6269

E-Mail:  
info-f@schneeberger.com

### GREAT BRITAIN

Mobile +44 77 8814 5645

E-Mail:  
info-uk@schneeberger.com

### ISRAEL

Mobile +972 5 0551 7920

E-Mail:  
info-il@schneeberger.com

### POLAND, SLOVAKIA, CZECH REPUBLIC

Mobile +420 6 0278 4077

E-Mail:  
info-cz@schneeberger.com

### RUSSIA, BELARUS, UKRAINE

Mobile +7 985 960 85 53  
Mobile +38 050 407 6789  
Mobile +37 529 860 0410

E-Mail:  
info-ru@schneeberger.com

### SPAIN, PORTUGAL ANDORRA

Mobile +34 69 559 05 99

E-Mail:  
info-es@schneeberger.com

### TURKEY

Mobile +90 545 320 83 55

E-Mail:  
info-tr@schneeberger.com